

# WE series / serileri

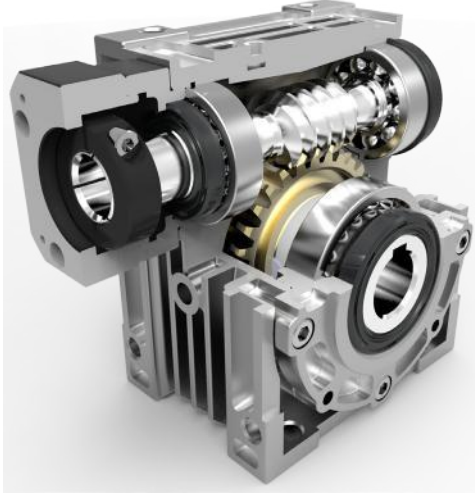

- Backlash  $\leq 8$  arcmin  
Boşluk Oranı  $\leq 8$  arcmin

## Indication of Model Numbers / Model Seçimi

WE	N		60	30	L	MOTOR
Type	Output Shaft / Çıkış Mili	Output Flange / Çıkış Flanşı	Model	Ratio / Çevrim	Shaft Dircetion / Mil Yönü	Motor Type / Motor Tipi
WE	S:Solid / Çıkış Millii	None / Flanşsız	30	1/5	R	Motor Brand & Model No. /
	O:Hollow / Delik Millii	F:Output Flange / Flanşlı	40	1/10	L	Motor Markası & Modeli
	N:Clamping / Konik Sıkmalı		50	1/15		
			60	1/20		
			70	1/30		
				1/40		
				1/50		
				1/60		

# Characteristic of WE Series / WE Serilerinin Özellikleri

## Shaft Direct / Çıkış Mili Yönü

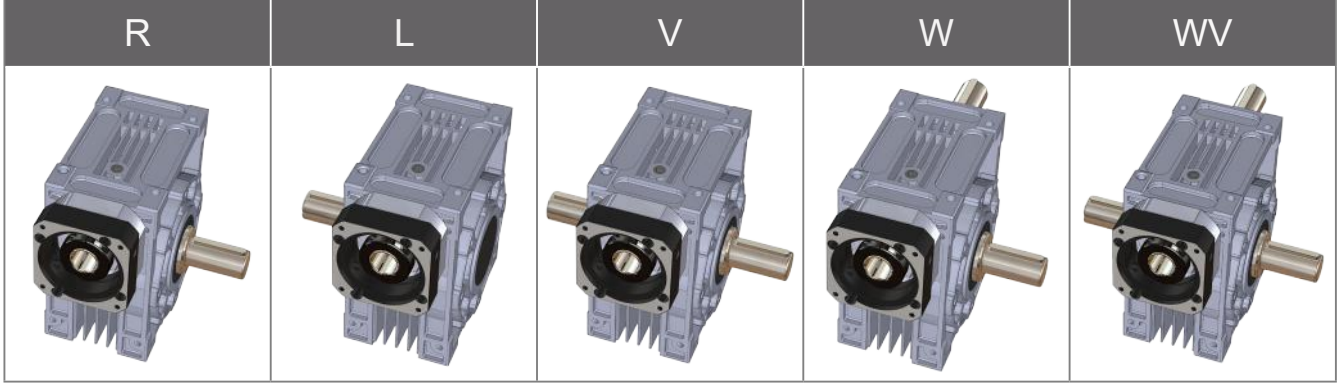

### Shaft Direction

- R : Right Shaft (input shaft to the face; output shaft to the right)  
L : Left Shaft (input shaft to the face; output shaft to the left)  
V : Single Input Shaft & Double Output Shaft  
W : Double Input Shaft & Single Output Shaft  
WV : Double Input Shaft & Double Output Shaft  
S : Special shaft (for any order, please specify your need clearly or attach drawings)

### Çıkış Mili Yönü

- R : Sağ Çıkış (giriş miline karşıdan bakıldığında)  
L : Sol Çıkış (giriş miline karşıdan bakıldığında)  
V : Tek Giriş Mili & Çift Çıkış Mili  
W : Çift Giriş Mili & Tek Çıkış Mili  
WV : Çift Giriş Mili & Çift Çıkış Mili  
S : Özel Üretim

### Rotary Direction

Upper worm for right-directed thread, so the input shaft is rotating clockwise and the output shaft counterclockwise; for any rotating direction required, be sure to specify it.

### Milin Dönüş Yönü

Giriş milinin saat yönünde hareketinde, çıkış milleri saat yönünün aksine hareket eder.

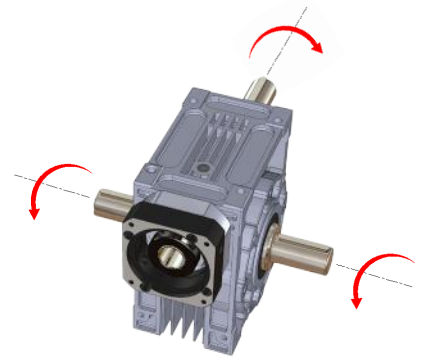
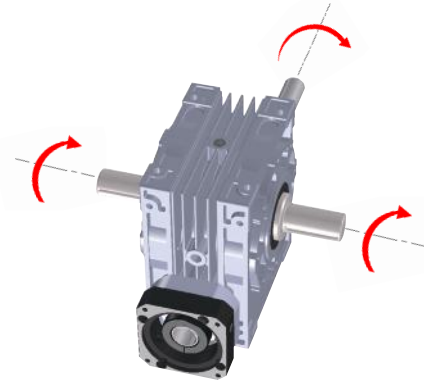

Rotation Direction /  
Milin Dönüş Yönü

# WE Series / Serileri



WES



WESF



WEO



WEOF



WEN



WENF

# WE Series / Serileri

Model No.		Unit Birim	Ratio Çevrim	30	40	50	60	70
Nominal output torque / Nominal Çıkış Torku	$T_{2N}$	Nm	5	8.3	22.3	30.6	41.2	70.6
				90.3	92.3	92.6	92.6	93.6
			10	8.8	20.7	41.9	65.9	92
				83.7	86.6	89.6	90.1	90.5
			15	11.4	26.2	40.9	64.5	90
				81.9	83.7	85.3	86.1	86.6
			20	9.52	22.6	40.7	63.5	106.1
				72.3	76.6	81.7	82.4	85.1
			30	12.1	27.4	43.2	67.9	95
				69.6	72.3	74.5	75.9	76.7
			40	9.2	24.3	43.8	69.1	111
				56.8	66.3	69.2	70.3	74.3
50	10.4	24	43.6	69.2	105.6			
	58.7	64.6	67.7	68.9	71.2			
60	9.6	20.5	36.1	58.3	100.5			
	54.6	56.8	59.3	61.3	68.8			
Max. Output Torque / Max.Çıkış Torku	$T_{2NOT}$	Nm	5~60	2 Times of Rated Output Torque / 2 x Nominal Çıkış Torku				
Rated Input Speed / Nominal Giriş Devri	$n_{1N}$	rpm	5~60	2,000				
Max. Input Speed / Max.Giriş Devri	$n_{1B}$	rpm	5~60	3,000				
Backlash / Boşluk Oranı		arcmin	5~60	$\leq 8$				
Max. Radial Force / Max. Radyal Yük	$F_{2rB}$	N	5~60	1,830	3,490	4,840	6,270	7,380
Max. Axial Force / Max. Aksiyel Yük	$F_{2aB}$	N	5~60	915	1,745	2,420	3,135	3,690
Service Life / Hizmet Ömrü	$L_H$	hr	5~60	S5 Döngüsel Çalışma : >12,000 (S1 Sürekli Çalışma : >6,000hrs) S5 Cycle Operation: >12,000 (S1 Continuous Operation: >6,000hrs)				
Operating Temperature / Çalışma Sıcaklığı		°C	5~60	-15° C ~ +50 ° C				
Lubrication / Yağlama			5~60	Synthetic Grease / Sentetik Yağ				
Protection Class / Koruma Sınıfı			5~60	IP65				
Mounting Position / Montaj Pozisyonu			5~60	Any / Her Yönde				

# WES series / serileri

RATIO / ÇEVİRİM : 5.10.15.20.30.40.50.60

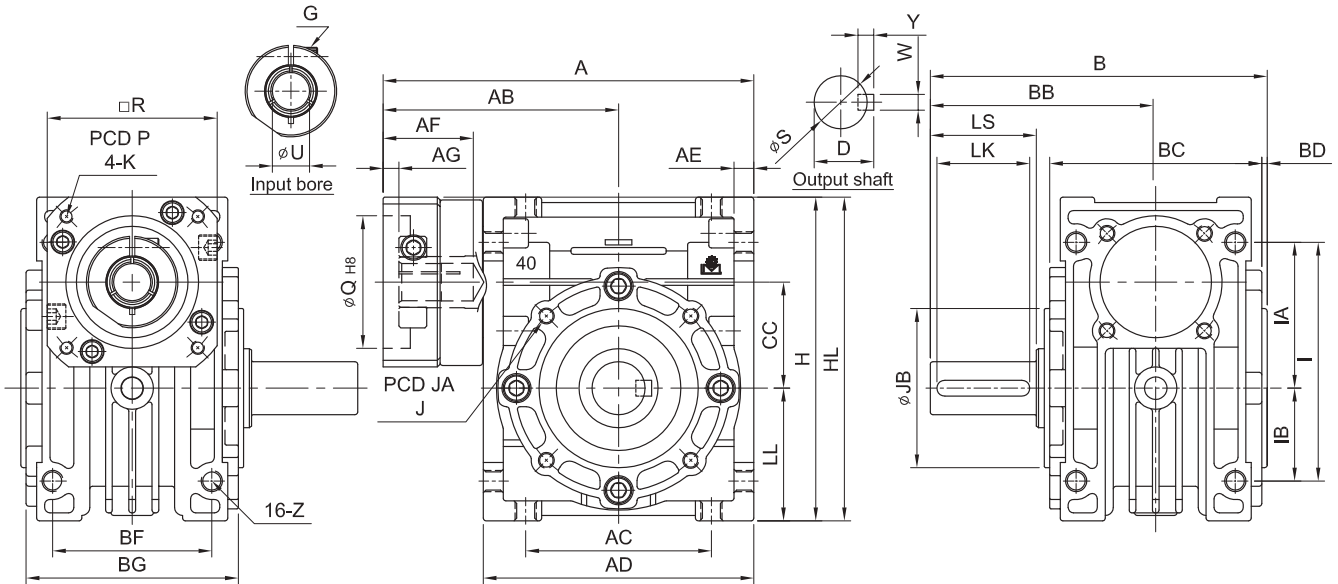

Model Code	A	AB	AC	AD	AE	AF	AG	B	BB	BC	BD	BF	BG	CC	LL	I	IA	IB	Z	H
30	108	68	55	80	6	32	5	99.5	67.5	60	2	45	58	30	40	72	45	27	M6	98
40	140	89	70	102	7.5	34	6	127	85	80	2	60	72	40	50	90	55	35	M8	122
50	158	98	80	120	8.5	34 · 41	6	150	100	94	3	70	85	50	60	105	65	40	M10	145
60	195	122	100	146	10	59	9	159	105	102	3	85	103	60	75	136	83	53	M10	180
70	219	134	120	170	12	54 · 59	9	187	125	118	3	90	110	70	85	150	90	60	M10	200

unit / birim : mm

Model Code	30	40	50	60	70
S	16	20	25	25	30
Y	5	6	7	7	7
W	5	6	8	8	8
D	18	22.5	28	28	33
LS	35	40	50	50	60
LK	30	35	45	45	55
J	8-M6 x P1.0	12-M6 x P1.0	12-M6 x P1.0	12-M8 x P1.25	12-M10 x P1.5
JA	65	77	95	120	140
JB	55	60	70	80	90
P	46 · 60 · 63	70 · 75 · 90	70 · 75 · 90	90 · 100 · 115 · 145	90 · 100 · 115 · 145
K	M3 x P0.5	M4 x P0.7	M4 x P0.7	M5 x P0.8	M5 x P0.8
	M4 x P0.7	M5 x P0.8	M5 x P0.8	M6 x P1.0	M6 x P1.0
	M5 x P0.8	M6 x P1.0	M6 x P1.0	M8 x P1.25	M8 x P1.25
R	46 · 55	64 · 70 · 80	64 · 70 · 80	92 · 110 · 130	92 · 110 · 130
G	M3 x P0.5	M5 x P0.8	M5 x P0.8	M6 x P1.0	M6 x P1.0
Q	30 · 40 · 50	50 · 60 · 70	50 · 60 · 70	70 · 80 · 95 · 110	70 · 80 · 95 · 110
U	8	14	14 · (19)	19 · (24)	19 · 24
HL	100	122 · 125 · 130	145 · 150	181 · 190 · 200	210 · 220

# WEO series / serileri

RATIO / ÇEVİRİM : 5.10.15.20.30.40.50.60

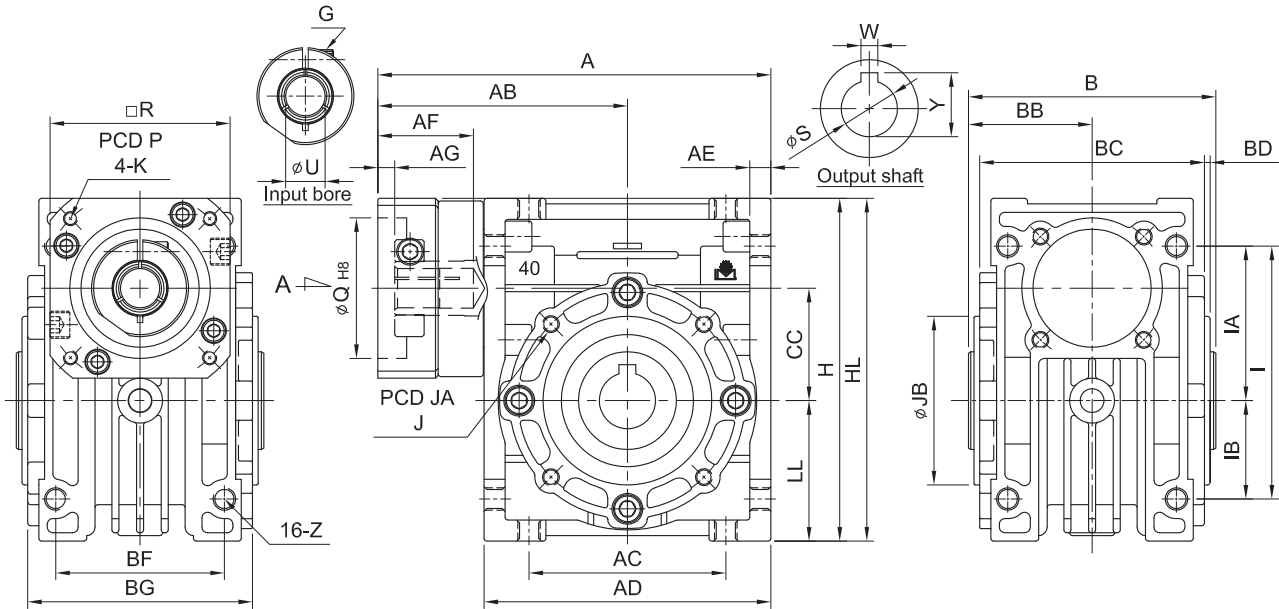

Model Code	A	AB	AC	AD	AE	AF	AG	B	BB	BC	BD	BF	BG	CC	LL	I	IA	IB	Z	H
30	108	68	55	80	6	32	5	65	32.5	60	2	45	58	30	40	72	45	27	M6	98
40	140	89	70	102	7.5	34	6	88	44	80	2	60	72	40	50	90	55	35	M8	122
50	158	98	80	120	8.5	34 - 41	6	98	50	94	3	70	85	50	60	105	65	40	M10	145
60	195	122	100	146	10	59	9	108	54	102	3	85	103	60	75	136	83	53	M10	180
70	219	134	120	170	12	54 - 59	9	128	64	118	3	90	110	70	85	150	90	60	M10	200

unit / birim : mm

Model Code	30	40	50	60	70
S	14	20	25	25	30
Y	16.3	22.8	28.3	28.3	33.3
W	5	6	8	8	8
J	8-M6 x P1.0	12-M6 x P1.0	12-M6 x P1.0	12-M8 x P1.25	12-M10 x P1.5
JA	65	77	95	120	140
JB	55	60	70	80	90
P	46 - 60 - 63	70 - 75 - 90	70 - 75 - 90	90 - 100 - 115 - 145	90 - 100 - 115 - 145
K	M3 x P0.5 M4 x P0.7 M5 x P0.8	M4 x P0.7 M5 x P0.8 M6 x P1.0	M4 x P0.7 M5 x P0.8 M6 x P1.0	M5 x P0.8 M6 x P1.0 M8 x P1.25	M5 x P0.8 M6 x P1.0 M8 x P1.25
R	46 - 55	64 - 70 - 80	64 - 70 - 80	92 - 110 - 130	92 - 110 - 130
G	M3 x P0.5	M5 x P0.8	M5 x P0.8	M6 x P1.0	M6 x P1.0
Q	30 - 40 - 50	50 - 60 - 70	50 - 60 - 70	70 - 80 - 95 - 110	70 - 80 - 95 - 110
U	8	14	14 - (19)	19 - (24)	19 - 24
HL	100	122 - 125 - 130	145 - 150	181 - 190 - 200	210 - 220



# WEN series / serileri

RATIO / ÇEVİRİM : 5.10.15.20.30.40.50.60

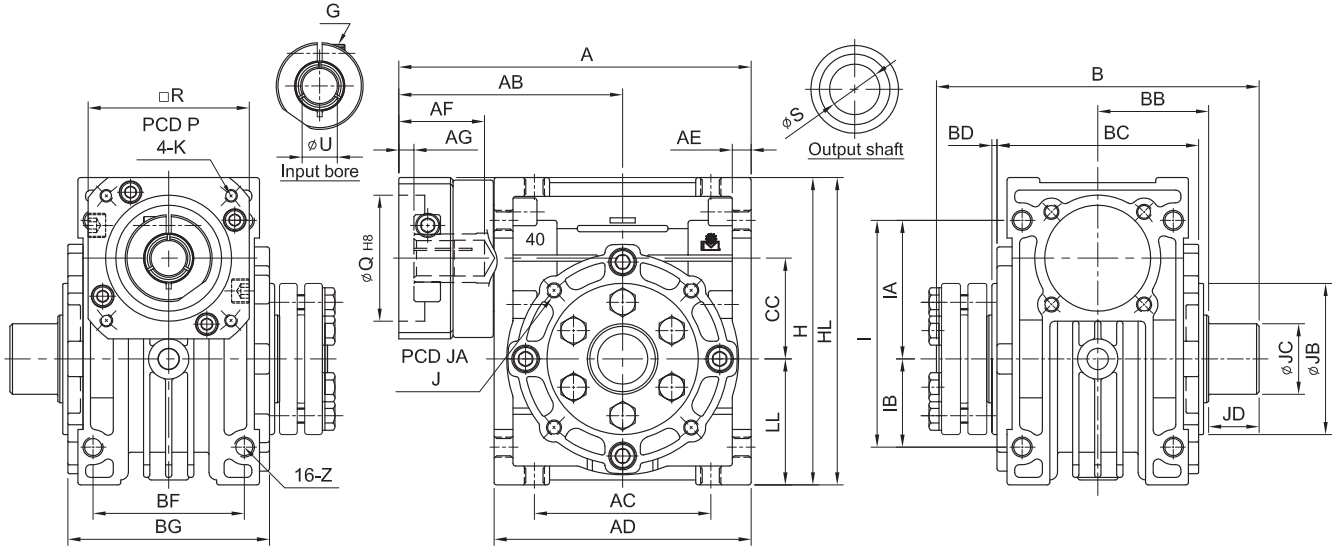

Model Code	A	AB	AC	AD	AE	AF	AG	B	BB	BC	BD	BF	BG	CC	LL	I	IA	IB	Z	H
30	108	68	55	80	6	32	5	108	36	60	2	45	58	30	40	72	45	27	M6	98
40	140	89	70	102	7.5	34	6	128	46	80	2	60	72	40	50	90	55	35	M8	122
50	158	98	80	120	8.5	34 · 41	6	146	53	94	3	70	85	50	60	105	65	40	M10	145
60	195	122	100	146	10	59	9	154	57	102	3	85	103	60	75	136	83	53	M10	180
70	219	134	120	170	12	54 · 59	9	172	65	118	3	90	110	70	85	150	90	60	M10	200

unit / birim : mm

Model Code	30	40	50	60	70
S	14	20	25	25	30
J	8-M6 x P1.0	12-M6 x P1.0	12-M6 x P1.0	12-M8 x P1.25	12-M10 x P1.5
JA	65	77	95	120	140
JB	55	60	70	80	90
JC	22	28	34	35	40
JD	18	18	20	20	21
P	46 · 60 · 63	70 · 75 · 90	70 · 75 · 90	90 · 100 · 115 · 145	90 · 100 · 115 · 145
K	M3 x P0.5 M4 x P0.7 M5 x P0.8	M4 x P0.7 M5 x P0.8 M6 x P1.0	M4 x P0.7 M5 x P0.8 M6 x P1.0	M5 x P0.8 M6 x P1.0 M8 x P1.25	M5 x P0.8 M6 x P1.0 M8 x P1.25
R	46 · 55	64 · 70 · 80	64 · 70 · 80	92 · 110 · 130	92 · 110 · 130
G	M3 x P0.5	M5 x P0.8	M5 x P0.8	M6 x P1.0	M6 x P1.0
Q	30 · 40 · 50	50 · 60 · 70	50 · 60 · 70	70 · 80 · 95 · 110	70 · 80 · 95 · 110
U	8	14	14 · (19)	19 · (24)	19 · 24
HL	100	122 · 125 · 130	145 · 150	181 · 190 · 200	210 · 220

# WESF series / serileri

RATIO / ÇEVİRİM : 5.10.15.20.30.40.50.60

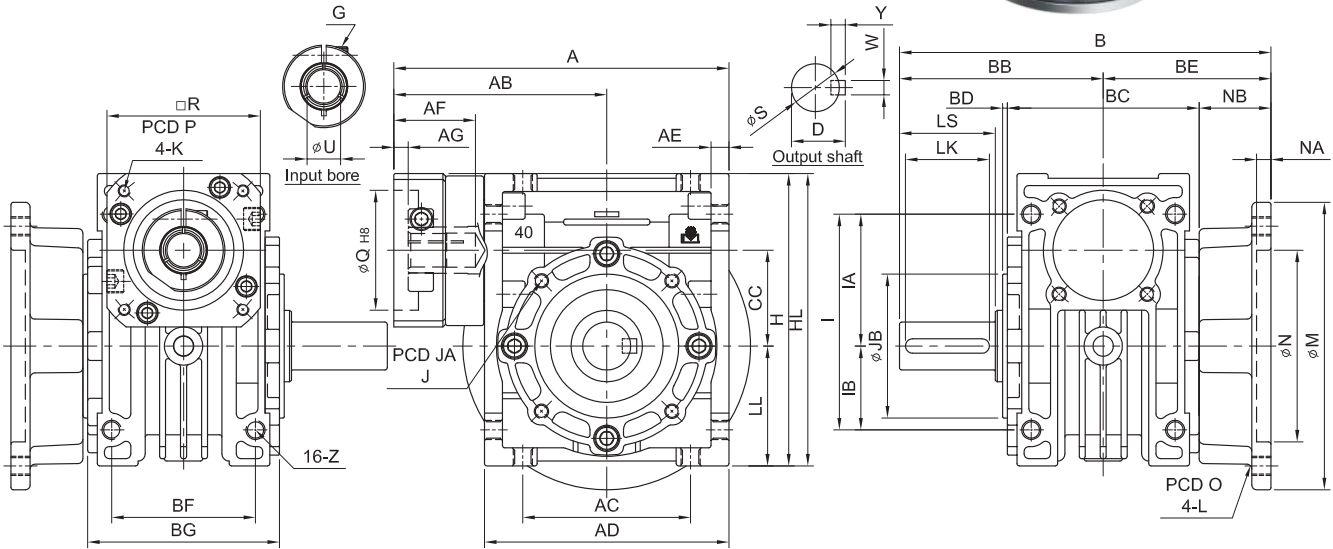

Model Code	A	AB	AC	AD	AE	AF	AG	B	BB	BC	BD	BE	BF	BG	NB	CC	LL	I	IA	IB	Z	H
30	108	68	55	80	6	32	5	127.5	67.5	60	2	60	45	58	30	30	40	72	45	27	M6	98
40	140	89	70	102	7.5	34	6	155	85	80	2	70	60	72	30	40	50	90	55	35	M8	122
50	158	98	80	120	8.5	34 · 41	6	180	100	94	3	80	70	85	33	50	60	105	65	40	M10	145
60	195	122	100	146	10	59	9	205	105	102	3	100	85	103	49	60	75	136	83	53	M10	180
70	219	134	120	170	12	54 · 59	9	225	125	118	3	100	90	110	41	70	85	150	90	60	M10	200

unit / birim : mm

Model Code	30	40	50	60	70
S	16	20	25	25	30
Y	5	6	7	7	7
W	5	6	8	8	8
D	18	22.5	28	28	33
LS	35	40	50	50	60
LK	30	35	45	45	55
J	8-M6 x P1.0	12-M6 x P1.0	12-M6 x P1.0	12-M8 x P1.25	12-M10 x P1.5
JA	65	77	95	120	140
JB	55	60	70	80	90
N	70	80	95	130	150
NA	5	6	6	7	7
O	85	100	120	160	185
L	M6 x P1.0	M8 x P1.25	M10 x P1.5	M10 x P1.5	M12 x P1.75
M	100	120	140	180	210
P	46 · 60 · 63	70 · 75 · 90	70 · 75 · 90	90 · 100 · 115 · 145	90 · 100 · 115 · 145
K	M3 x P0.5 M4 x P0.7 M5 x P0.8	M4 x P0.7 M5 x P0.8 M6 x P1.0	M4 x P0.7 M5 x P0.8 M6 x P1.0	M5 x P0.8 M6 x P1.0 M8 x P1.25	M5 x P0.8 M6 x P1.0 M8 x P1.25
R	46 · 55	64 · 70 · 80	64 · 70 · 80	92 · 110 · 130	92 · 110 · 130
G	M3 x P0.5	M5 x P0.8	M5 x P0.8	M6 x P1.0	M6 x P1.0
Q	30 · 40 · 50	50 · 60 · 70	50 · 60 · 70	70 · 80 · 95 · 110	70 · 80 · 95 · 110
U	8	14	14 · (19)	19 · (24)	19 · 24
HL	100	122 · 125 · 130	145 · 150	181 · 190 · 200	210 · 220



# WEOF series / serileri

RATIO / ÇEVİRİM : 5.10.15.20.30.40.50.60

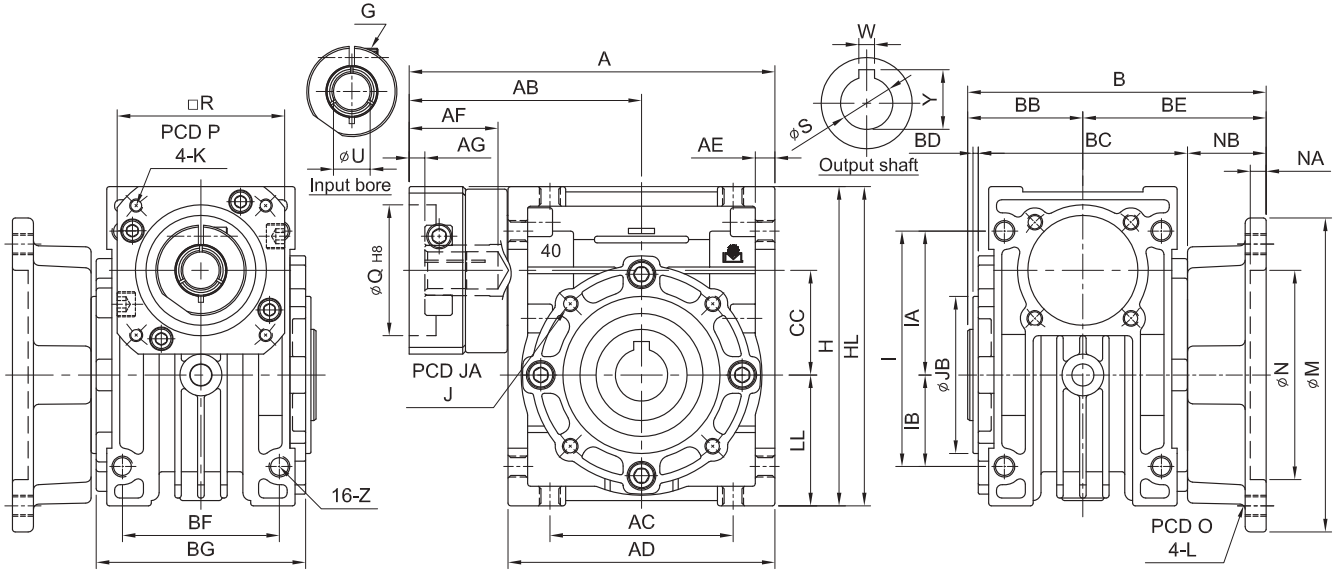

Model Code	A	AB	AC	AD	AE	AF	AG	B	BB	BC	BD	BE	BF	BG	NB	CC	LL	I	IA	IB	Z	H
30	108	68	55	80	6	32	5	92.5	32.5	60	2	60	45	58	30	30	40	72	45	27	M6	98
40	140	89	70	102	7.5	34	6	114	44	80	2	70	60	72	30	40	50	90	55	35	M8	122
50	158	98	80	120	8.5	34 - 41	6	130	49	94	3	80	70	85	33	50	60	105	65	40	M10	145
60	195	122	100	146	10	59	9	154	54	102	3	100	85	103	49	60	75	136	83	53	M10	180
70	219	134	120	170	12	54 - 59	9	164	64	118	3	100	90	110	41	70	85	150	90	60	M10	200

unit / birim : mm

Model Code	30	40	50	60	70
S	14	20	25	25	30
Y	16.3	22.8	28.3	28.3	33.3
W	5	6	8	8	8
J	8-M6 x P1.0	12-M6 x P1.0	12-M6 x P1.0	12-M8 x P1.25	12-M10 x P1.5
JA	65	77	95	120	140
JB	55	60	70	80	90
N	70	80	95	130	150
NA	5	6	6	7	7
O	85	100	120	160	185
L	M6 x P1.0	M8 x P1.25	M10 x P1.5	M10 x P1.5	M12 x P1.75
M	100	120	140	180	210
P	46 - 60 - 63	70 - 75 - 90	70 - 75 - 90	90 - 100 - 115 - 145	90 - 100 - 115 - 145
K	M3 x P0.5 M4 x P0.7 M5 x P0.8	M4 x P0.7 M5 x P0.8 M6 x P1.0	M4 x P0.7 M5 x P0.8 M6 x P1.0	M5 x P0.8 M6 x P1.0 M8 x P1.25	M5 x P0.8 M6 x P1.0 M8 x P1.25
R	46 - 55	64 - 70 - 80	64 - 70 - 80	92 - 110 - 130	92 - 110 - 130
G	M3 x P0.5	M5 x P0.8	M5 x P0.8	M6 x P1.0	M6 x P1.0
Q	30 - 40 - 50	50 - 60 - 70	50 - 60 - 70	70 - 80 - 95 - 110	70 - 80 - 95 - 110
U	8	14	14 - (19)	19 - (24)	19 - 24
HL	100	122 - 125 - 130	145 - 150	181 - 190 - 200	210 - 220

# WENF series / serileri

RATIO / ÇEVİRİM : 5.10.15.20.30.40.50.60

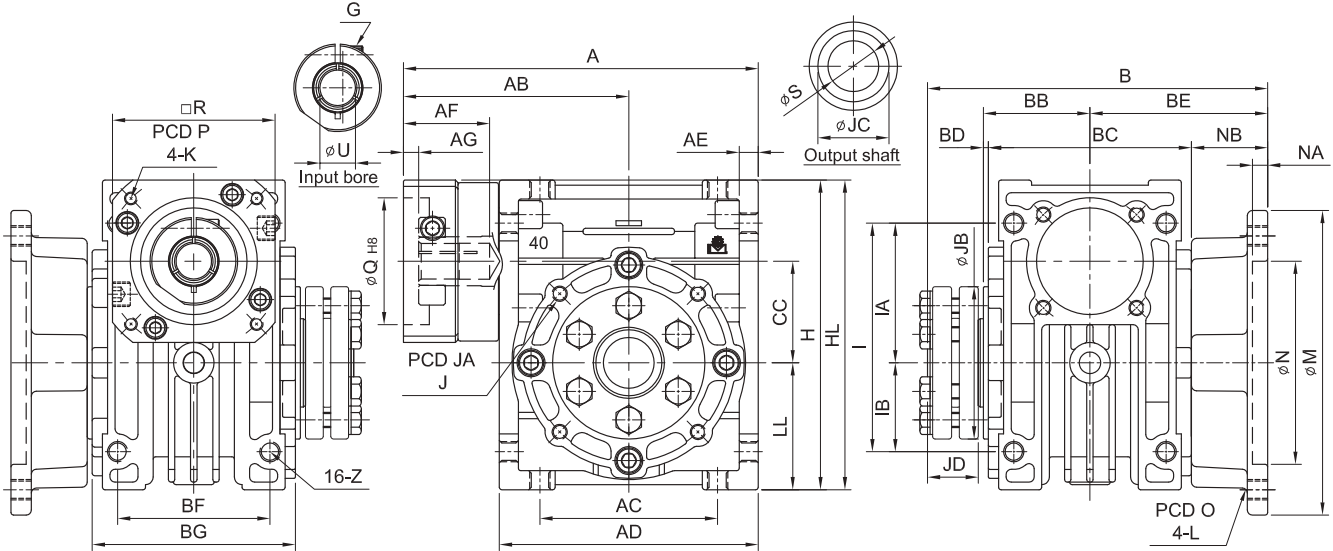

Model Code	A	AB	AC	AD	AE	AF	AG	B	BB	BC	BD	BE	BF	BG	NB	CC	LL	I	IA	IB	Z	H
30	108	68	55	80	6	32	5	114	32.5	60	2	60	45	58	30	30	40	72	45	27	M6	98
40	140	89	70	102	7.5	34	6	134	44	80	2	70	60	72	30	40	50	90	55	35	M8	122
50	158	98	80	120	8.5	34 · 41	6	153	49	94	3	80	70	85	33	50	60	105	65	40	M10	145
60	195	122	100	146	10	59	9	177	54	102	3	100	85	103	49	60	75	136	83	53	M10	180
70	219	134	120	170	12	54 · 59	9	186	64	118	3	100	90	110	41	70	85	150	90	60	M10	200

unit / birim : mm

Model Code	30	40	50	60	70
S	14	20	25	25	30
J	8-M6 x P1.0	12-M6 x P1.0	12-M6 x P1.0	12-M8 x P1.25	12-M10 x P1.5
JA	65	77	95	120	140
JB	55	60	70	80	90
JC	22	28	34	35	40
JD	20	20	21	21	22
N	70	80	95	130	150
NA	5	6	6	7	7
O	85	100	120	160	185
L	M6 x P1.0	M8 x P1.25	M10 x P1.5	M10 x P1.5	M12 x P1.75
M	100	120	140	180	210
P	46 · 60 · 63	70 · 75 · 90	70 · 75 · 90	90 · 100 · 115 · 145	90 · 100 · 115 · 145
K	M3 x P0.5 M4 x P0.7 M5 x P0.8	M4 x P0.7 M5 x P0.8 M6 x P1.0	M4 x P0.7 M5 x P0.8 M6 x P1.0	M5 x P0.8 M6 x P1.0 M8 x P1.25	M5 x P0.8 M6 x P1.0 M8 x P1.25
R	46 · 55	64 · 70 · 80	64 · 70 · 80	92 · 110 · 130	92 · 110 · 130
G	M3 x P0.5	M5 x P0.8	M5 x P0.8	M6 x P1.0	M6 x P1.0
Q	30 · 40 · 50	50 · 60 · 70	50 · 60 · 70	70 · 80 · 95 · 110	70 · 80 · 95 · 110
U	8	14	14 · (19)	19 · (24)	19 · 24
HL	100	122 · 125 · 130	145 · 150	181 · 190 · 200	210 · 220